

To: All Nanofab Users  
From: Jack Whaley  
ESB Room 1109B, Ext 8174  
Date: March 9, 2012  
RE: Nanofabrication Facility  
Policy, Guidelines, and  
Chemical Hygiene Plan

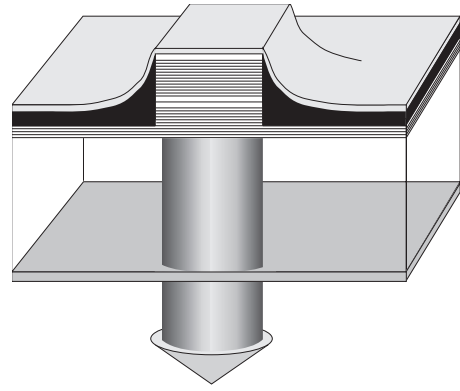

While working in the Nanofab, you are surrounded by dangerous and deadly chemicals, gases, high voltages, radiation, and mechanical systems. The responsibility lies with users and staff to act in a professional, courteous, and safe manner at all times while in the facility. Users violating the operating and safety rules of the facility or endangering the safety of themselves or other users will be denied further access to the facility.

This document attempts to define acceptable actions and behavior for the users of the Nanofabrication facility. However, it is impossible to define a policy for every conceivable situation. Nanofab users are expected to employ common sense and a high degree of prudence while working in this facility.

## 1. General Nanofabrication Facility Safety Policies

### 1.1. Visual and Audible Alarms in the Nanofab

- 1.1.1. **Fire Alarm:** White strobe with high volume audible alarm, located throughout the Nanofab. If this alarm activates, immediately leave the Nanofab through the nearest exit. Do not remove bunnysuit until outside.
- 1.1.2. **Toxic Gas Alarm:** Blue strobe with high volume audible alarm, located at both ends of each bay. If this alarm activates in one bay, do not enter the bay. If this alarm activates throughout the Nanofab, immediately leave the Nanofab through the nearest exit. Do not remove bunnysuit until outside.
- 1.1.3. **Wet Bench Alarms:** Small illuminated visual alarms with buzzers. Each wet bench may have multiple alarms, with a placard beside the alarms indicating meaning of alarm and proper response. You must follow proper response if you see or hear a wet bench alarm.
- 1.1.4. **Equipment Alarms:** Please notify supervisor of tool if equipment alarm is activated.

## 1.2. Emergencies and First Aid

1.2.1. **If you believe you may have been exposed to a toxic substance or gas, if appropriate rinse in the emergency shower. In all cases, quickly go to the emergency room at Goleta Valley Hospital.** Emergency showers and eye wash stations are located at the south end of all bays. An enclosed emergency showers is located in bay 5 beside the wet etch benches. A first aid kit is located in the gowning room, and on the south wall at the end of bays 2, 4, and 6. Chemical spill clean-up kits are located on the wire shelving in each bay containing a wet bench. After using a spill cleanup kit, please inform the Nanofab manager. Fire extinguishers are located on the south end of each clean bay, and the north end of each maintenance chase.

## 1.3. Hydrofluoric Acid (HF) Exposure

### 1.3.1. HF Exposure to Skin

- 1.3.1.1. Immediately rinse exposed area for 5 minutes in safety shower, flush affected area thoroughly. Speed and thoroughness in washing off the acid is of primary importance. An enclosed emergency showers is located in bay 5 across from the HF/TMAH wet processing bench. If using the emergency shower at the end of the bay, water will spill onto floor of Nanofab - this is OK.
- 1.3.1.2. Immediately after rinsing, start massaging 2.5% calcium gluconate gel into the affected area. The individual applying the gel should wear gloves. Apply gel frequently and massage continuously. Calcium gluconate gel is located to the left of the HF bench in a pocket mounted to the side of the bench.
- 1.3.1.3. Seek immediate medical attention by calling 9-911.
- 1.3.1.4. Continue rubbing gel on affected area until advised otherwise by physician.

### 1.3.2. HF Exposure to Eyes

- 1.3.2.1. Immediately rinse exposed area for 15 minutes at eye wash station. Hold eyelids open during irrigation to allow thorough flushing of the eyes. Water will spill onto floor of Nanofab - this is OK.
- 1.3.2.2. Seek immediate medical attention by calling 9-911.

## 1.4. TetraMethylAmmonium Hydroxide (TMAH) Exposure

TMAH is a component in several photoresist developers and strippers, and is also used in the Nanofab as an ebeam resist developer and silicon etchant. The concentration of TMAH in photoresist developer and stripper solutions is relatively low (2-4%). However, the ebeam developer and silicon etchant utilize a solution of 25% TMAH.

**1.4.1. TMAH Exposure to Skin, 25% Concentration**

1.4.1.1. Immediately rinse exposed area for at least 15 minutes in safety shower, flush affected area thoroughly. An enclosed emergency showers is located in bay 5 across from the HF/TMAH wet etch bench. If using the emergency shower at the end of the bay, water will spill onto floor of Nanofab - this is OK.

1.4.1.2. Seek immediate medical attention by calling 9-911

**1.4.2. TMAH Exposure to Skin, 2%-4% Concentration**

1.4.2.1. If small area skin exposure (<1% body surface area, <approximately 25 inches<sup>2</sup>) to 2-4% TMAH, immediately rinse exposed area until skin feels normal (not greasy). If irritation occurs, consult a physician.

1.4.2.2. If medium to large area skin exposure (>1% body surface area, >approximately 25 inches<sup>2</sup>) to 2-4% TMAH, immediately rinse exposed area for at least 15 minutes in safety shower, flush affected area thoroughly. An enclosed emergency showers is located in bay 5 across from the HF/TMAH wet etch bench. If using the emergency shower at the end of the bay, water will spill onto floor of Nanofab - this is OK. Seek immediate medical attention by calling 9-911.

**1.4.3. TMAH Exposure to Eyes, Any Concentration**

1.4.3.1. Immediately rinse exposed area for at least 15 minutes at eye wash station. Hold eyelids open during irrigation to allow thorough flushing of the eyes. Water will spill onto floor of Nanofab - this is OK.

1.4.3.2. Seek immediate medical attention by calling 9-911

**1.5. Pregnancy and the Nanofab**

1.5.1. The effects on a fetus of many of the chemicals utilized in the Nanofab is unknown. The Nanofab is designed to prevent exposure to the fumes and vapors from these chemicals, but absolute 100% containment is impossible, and it is possible to be exposed to extremely small concentrations of these materials. Consequently, we strongly recommend that you do not work in the Nanofab if you know or suspect that you are pregnant.

## 2. Chemicals and Hazardous Materials the Nanofab

### 2.1. MSDS

2.1.1. The MSDS contains safety information regarding exposure, first aid, handling, storage, fire hazard, etc., for all chemicals, gases, and materials present in the facility. Before using an unfamiliar material, consult the MSDS to determine any potential hazards. Consult the MSDS to determine the proper course of action if someone has been exposed to a gas or chemical, or a spill has occurred. A book containing the MSDS for any material used in the Nanofab is located just inside the gowning room. Additionally, an electronic version of the MSDS in .pdf format for all chemicals in our inventory is located on the desktops of all the computers connected to microscopes in the Nanofab.

### 2.2. Introducing New Materials Into the Nanofab

2.2.1. All new chemicals, compounds, gases, materials for evaporation, etc., must be approved by the Nanofab manager before introduction into the facility. In order to introduce a new material into the Nanofab, a MSDS (Material Safety Data Sheet) for the material in .pdf format must be submitted to the Nanofab manager, plus a description of the proposed process utilizing the new material. The description of the process should include the goals of the process, and the mechanics of the process in reasonable detail. The Nanofab manager will determine if the material will be allowed in the Nanofab, and if so, where the new material will be stored, where the material is to be used (typically a specific wet bench), and how to dispose of the waste.

### 2.3. Containers and Labeling

2.3.1. Chemical containers such as beakers, bottles, etc, must be labeled with **contents, date, and ownership (individual or group name)**. This information can be written on a wipe under the container. The exceptions to this policy are as follows:

2.3.1.1. A beaker in use on a solvent bench can contain acetone, propanol, or methanol if the beaker is labeled with the text: "acetone / propanol / methanol". The generic label "solvent" is insufficient. Beakers containing solvents other than acetone, propanol, or methanol must be labeled with the specific solvent.

2.3.1.2. Indication of date is no longer required on beakers in use on solvent benches. All beakers in use on solvent benches must be labeled with contents and ownership.

2.3.1.3. Beakers in use at lithography developer benches must be labeled with exact contents and ownership (individual or group name). The generic label "developer" is insufficient.

2.3.1.4. Indication of date is no longer required on beakers in use on the developer benches. All beakers in use on developer benches must be labeled with contents and ownership.

## 2.4. Chemical Storage

### 2.4.1. Acid Storage

The primary acid storage area (except HF) is the acid cabinet located next to the acid wet processing benches in bay 5. HF acid is stored in the HF cabinet

### 2.4.2. Base Storage

The primary base storage area is the base cabinet located next to the acid wet processing bench.

### 2.4.3. Solvent Storage

The primary solvent storage area is the stainless steel flammables cabinet in bay 6. You may store small amounts of solvents in labeled containers on the shelves in the photolith area.

## 2.5. Solvent Processing

2.5.1. Solvents with flashpoints below 55 deg C cannot be heated in the Nanofab. This includes acetone, methanol, isopropanol, ethanol, and toluene. All solvent processing is limited to the stainless steel solvent processing benches. Do not perform standard solvent processing at the photoresist spinner benches.

## 2.6. Wet Etch and HF/TMAH Processing

2.6.1. All wet processing involving acids and bases (except HF and TMAH) is limited to the acid/base benches. All HF and Bromine processing is limited to the HF or HF/TMAH benches - NO EXCEPTIONS. All TMAH processing is limited to the HF/TMAH bench. When working at the HF or HF/TMAH benches, always wear a chemical apron, face shield, and "Trionic" gloves. Store all HF and bromine in labeled containers in the HF acid/bromine storage cabinet. Store TMAH in the base storage cabinet. Please keep open containers of these two toxic chemicals away from the edge of the bench. All waste solutions containing any HF is poured down the drain, and treated in the Nanofab acid treatment system. Empty HF bottles should be returned to the HF acid storage cabinet. You may not deviate from this policy unless you have prior approval by the Nanofab manager.

## 2.7. Photoresist Coating or Spinning

2.7.1. Standard solvent-based photoresist spinning should be performed at the PR spinner benches. Some lithography chemicals utilize non-standard chemicals in place of solvents, which may require spinning at a different bench. If using a non-standard lithography chemicals, please provide the MSDS and process instructions to the laboratory manager for direction in this matter.

## 2.8. Developer Benches

2.8.1. Developer benches are used for developing photoresists only. In general, solvents are not allowed at the developer benches because solvent fumes adversely affect the develop process. Solvent based liftoff processes are not allowed at the developer benches. E-beam develop processes may utilize solvents, and should be performed at the solvent benches in the photolith area.

## 2.9. Plating Bench

2.9.1. **The Solvent/Plating bench contains cyanide-based plating and etching solutions. Never use acid solutions at this bench.**

## 2.10. Photoresist Storage, Handling, and Waste

2.10.1. Photoresists can contain many solvents and aromatics that are potentially toxic. Special care must be exercised when handling these materials. All photoresist fumes must be exhausted or otherwise contained through careful procedures at the photolith wet benches. The primary photoresist storage area is the lab refrigerator located bay 6. Some resists do not need refrigeration and are stored in the flammables cabinet next to the refrigerator (PMGI, PMMA, etc). Before transferring refrigerated PR from the main bottle to your in-use bottle, place main bottle on designated photoresist warming racks for a minimum of 2 hours, or until the bottle is at room temperature, whichever is longer. Large transfer pipettes are provided for transferring PR from the main bottle to your in-use bottle. To prevent PR flakes from contaminating the main bottle, please inspect the main bottle cap and bottle threads for PR, and remove any PR with an acetone wipe before replacing cap. After transfer, place main bottle back in the refrigerator. You may store your in-use, fully labeled PR bottle in the stainless steel PR storage cabinet in a bin labeled with your research group name. Disposable droppers, syringes, and filters are provided for the application of photoresist on your substrate. You may store photoresist in the PR storage cabinet for a maximum of 6 months. Nanofab staff will remove in-use PR bottles older than 6 months, and will also remove any bottle not correctly labeled with contents, date, and ownership. Nanofab wipes and pipettes contaminated with PR must be placed in the beakers at the back of the spinner benches. **Do not place PR contaminated materials in the trashcans, as this will allow photoresist fumes to migrate throughout the photolith area.** Dispose of waste photoresist bottles by placing your labeled bottle in the yellow solvent waste cabinet in chase 5.

## 2.11. Photoresist Strippers

2.11.1. Use of heated strippers is limited to the stainless steel solvent benches. It is recommended you use the heated water bath to heat your stripper to 80 C. If you choose to use a hot plate to heat commercial photoresist strippers, we realize the hot plate surface temperature will need to be set above 80 C. Ideally, you should use a temperature probe inserted in the liquid as the feedback control for the hot plate. If you have the hot plate surface temperature set above 80 C, you must actively monitor the temperature of the stripper using a thermometer (or equivalent) and limit the stripper temperature to a maximum of 80 degrees C. You must be in the vicinity of the hotplate whenever you are heating strippers with the hot plate surface set above 80 degrees C if you are not using a temperature probe for feedback control of the hot plate.

2.11.2. The following photoresist strippers are stocked:

2.11.2.1. Shipley 1165

2.11.2.2. AZ 300T

2.11.2.3. Shipley SVC-14

2.11.2.4. PRX-127

## 2.12. Chemical Waste Disposal

### 2.12.1. General Guidelines

2.12.1.1. The correct method of disposal for any chemical waste in our inventory is posted throughout the Nanofab, and also indicated in a file titled "Nanofab Chemical Storage/Use/Disposal", located on the desktops of all optical microscope computers in the Nanofab.

2.12.1.2. **DO NOT DISPOSE OF SOLVENTS IN THE ACID DRAIN, OR ACIDS AND BASES IN THE SOLVENT DRAINS DUE TO POSSIBLE EXPLOSION OR THE CREATION OF OTHER HAZARDOUS SITUATIONS.**

2.12.2. All chemical waste is disposed in one of three methods:

#### 2.12.2.1. Acid Drains

Most (but not all) water-based chemicals use this method. The acid drain empties into a waste chemical pH neutralization system located in the Nanofab mechanical room. This is the primary drain in the Nanofab. All liquids entering the sink drain at any polypropylene wet bench in the Nanofab run through this treatment system.

To dispose of an acid or base, pour the liquid down the drain **using the plenum flush**. If you spill an acid or base onto the top surface of a bench, first rinse the surface thoroughly with water, then turn on the plenum flush to rinse the bench drain. Do not pour solvents down the acid drain.

#### 2.12.2.2. Solvent Drains

Most (but not all) solvent waste use this method. The solvent drain waste is pumped to a storage tank located in the Nanofab mechanical room. The waste solvents are transported to the EH&S chemical waste processing facility.

#### 2.12.2.3. Collection of Waste

Always fill out the Environmental Health and Safety waste disposal form when storing waste chemicals in the appropriate cabinet.

2.13. **Disposing of Empty Acid, Base, and Solvent Bottles**

Thoroughly rinse empty acid and base bottles three times with DI water, and then place in a trashcan. Place completely empty solvent bottles in the trashcan, making sure caps are in place. The exception to this policy is empty 49% HF bottles, which should be returned to the HF storage cabinet.

3. **Nanofab Apparel and Gloves**

3.1. **Bunnysuits and Booties**

You must wear a full bunnysuit to enter the Nanofab (hood, coverall, shoe covers). Facial covers are optional. Change bunnysuits weekly if used often, or at least once a month if used sporadically. Store coverall and hoods on numbered hangers in the gowning room. Reserve a hanger by placing a stainless steel “hanger reserve clip” on the hanger number. Store booties in the corresponding numbered slot in the bootie storage rack. Sandals or any other open toed shoes are not allowed in the Nanofab at any time.

3.2. **Eye Protection**

ANSI-approved eye protection must be worn at all times in the Nanofab, except when using optical microscopes. All eye protection eyewear must be ANSI-approved, as indicated by the “Z87” stamp required on the eyewear. You are welcome to use personal prescription safety eyewear which is ANSI-approved. Three types of safety eyewear are stocked in the Nanofab:

3.2.1. Uvex Astro 3000, for use by people who do not wear vision correction glasses. These safety glasses have a black frame.

3.2.2. Uvex Astro OTG 3001, for use by people who do wear vision correction glasses. These safety glasses are intended to be worn over vision correction glasses, and have a blue frame.

3.2.3. U.S. Safety Faceshield. This full faceshields must be worn when working with dangerous chemicals or materials. Always use a faceshield when working at the HF bench.

3.3. **Aprons and Gloves**

3.3.1. **General Information**

Always wear gloves when in the Nanofab. Acid aprons are required when handling HF and other highly corrosive or toxic chemicals.



3.3.2. **Five types of gloves are available in the Nanofab:**

Material	Manufacturer/Model	Color	Thickness	Stocked Sizes
PVC	Kimtech G5 Co-Polymer	Clear	0.10mm (4 mil)	S, M, L, XL
Latex	Kimtech G3 Latex	Tan	0.20mm (8 mil)	6, 6.5, 7, 7.5, 8, 8.5, 9, 10
Nitrile	Best CleaN-Dex Ultimate	White	0.15mm (6 mil)	XS, S, M, L, XL
Nitrile	MAPA StanSolve A-30	Green	0.28mm (11 mil)	7, 8, 9, 10, 11
Blend	MAPA TRIonic E-194	Tan	0.50mm (20 mil)	6, 7, 8, 9, 10, 11

3.3.2.1. Polyvinyl Chloride (PVC): **Kimtech G5 Co-Polymer**

A relatively inexpensive static free general-purpose glove, poor for most organics. These gloves break down rapidly in acetone.

3.3.2.2. Latex: **Kimtech G3 Latex**

A general-purpose glove, poor for most organics, okay with aldehydes and ketones.

3.3.2.3. Nitrile, White: Best **CleaN-Dex Ultimate**

This thin general purpose low cost glove offers marginal protection from many ketones, okay with some acids and bases.

3.3.2.4. Nitrile, Green: MAPA **StanSolve A-30**

A thicker nitrile glove that affords increased protection over the CleaN-Dex white nitrile glove.

3.3.2.5. Nitrile/Neoprene/Latex Blend: MAPA **TRIonic E-194**

This glove is the standard wet processing glove. A blend of latex, neoprene, and carboxylated nitrile, which offers excellent protection from corrosives and solvents such as HF and acetone. Highly resistant to cuts, tears, and snags. Always use this glove when processing with HF, TMAH, or Bromine.

## 4. General Nanofab Information

### 4.1. Iris Camera Access System

4.1.1. The iris camera access system provides security to the Nanofab, and allows tracking of the time each user spends in the Nanofab. **ALWAYS** scan in when entering the lab and scan out when exiting the lab, even when attending training sessions or performing beneficial work. Violating this policy will result in a two-week suspension for the first incidence, and possible permanent suspension for recurring incidences.

## 4.2. Scheduling Tool/Equipment Use and Tool Supervisors

4.2.1. Tool use is scheduled in one of two ways:

1) either through the web-based system “Signupmonkey” at URL:

<http://signupmonkey.ece.ucsb.edu>

2) or first come/first served

4.2.2. If a tool is listed on Signupmonkey, you must obtain permission from the supervisor of the tool in order to schedule use of the tool. This is typically accomplished by attending a training session.

4.2.3. Some tools are not scheduled using Signupmonkey because the cycle period is typically short and use of the tool is most efficient without using signupmonkey.

4.2.4. All tools in the Nanofab have a supervisor, regardless of whether the tool is listed on Signupmonkey.

4.2.5. If you have problems with any tool, please inform the supervisor either by email, or direct communication (phone, etc).

## 4.3. Credit for Beneficial Work in the Nanofab

4.3.1. You will receive 1.5 hours of free processing time for each hour spent performing maintenance on lab equipment, conducting training sessions, or any time spent performing work beneficial to the general operation of the lab. Please indicate time spent performing beneficial work on the sign-up sheet just inside the gowning room.

## 4.4. Wet Bench Housekeeping

4.4.1. Always leave wet benches **clean, dry, and organized**. This includes cleaning up all spills, storing glassware and chemicals, etc. If a bench is not clean when you start a task, you still have the responsibility to leave it clean. **If you leave a wet bench in disarray, or leave an unlabeled container on a bench, you can be suspended from the Nanofab.** Do not cover the exhaust holes on the bench tops, as this will impede the laminar flow of air through the bench and possibly expose you or other Nanofab users to toxic fumes.

## 4.5. Hotplates

4.5.1. Hot plates used for heating chemicals must be attended. This means you must be in the Nanofab and near the hot plat whenever it is in use. (This does not apply to PR baking hotplates on the PR spinner benches.)

#### 4.6. Nanofab Paper

- 4.6.1. The only paper allowed in the lab is Nanofab type paper. We stock many different types of Nanofab paper for the lab, including photocopier (or laserwriter) paper, sticky labels, and assorted notebooks. If you require a special type of Nanofab paper, ask and we will try to obtain it. You can laminate regular paper for use in the lab. Use pens, not pencils, for writing in the lab.

#### 4.7. Nanofab Wipes

- 4.7.1. We stock four types of wipes in the lab

4.7.1.1. **S/Pec-Wipe 3** is a cellulose / polyester blend with high absorption but medium particle and fiber generation.

4.7.1.2. **Berkshire Poly1200** is a 100% knit polyethylene wipe with low particulate generation, but also with relatively low absorption.

4.7.1.3. **PRO-STAT** is a cellulose blend presaturated with isopropyl alcohol and DI water.

4.7.1.4. **BIOHAZ** are used to line photoresist spinner catch cups

#### 4.8. Preparing Equipment for Entry into the Nanofab

- 4.8.1. All equipment entering the lab must be clean. The procedure for cleaning equipment for entry is:

4.8.1.1. Vacuum while equipment is outside the lab

4.8.1.2. Wipe down all accessible surfaces with propanol or EKC "Lab Clean" using Nanofab wipes while equipment is outside the lab

4.8.1.3. Move equipment into the lab

4.8.1.4. Vacuum with HEPA filtered vacuum cleaner when inside the lab

#### 4.9. Maintenance Ways

- 4.9.1. You may enter maintenance ways without wearing a bunnysuit from outside the Nanofab, or while wearing a bunnysuit from inside the Nanofab.

#### 4.10. Notes on Particle Counts in the Nanofab

- 4.10.1. The Nanofab was surveyed with a particle counter, with generally good results. All wet bench work surfaces have extremely low particle counts, better than class 10. The open areas in the lithography area are all better than class 100, and mostly better than class 10. The remainder of the Nanofab tests better than class 1000, and often better than class 100. The Nanofab design specifications stipulated class 100 for litho, class 1000 for everything else. The Nanofab is easily meeting these specs.

4.10.2. The effectiveness of facemasks was investigated by placing the particle counter directly under a person's neck while the person moved his head back and forth. Facemasks reduced particle counts, from the equivalent of class 500 without masks to class 100 with masks. Again, this was sampling just below the neck, not at typical substrate surfaces.

4.10.3. The choice of wipes used in the Nanofab has a more pronounced affect on particle counts. In general, wipes trade absorbency for low particle generation. The Spec-Wipe 3 is the stocked polyester/cellulose blend, high absorbency wipe designed for use in class 100 cleanrooms. Dragging the sampling tube across the surface of a Spec-Wipe 3 resulted in a class 1000 level particle counts. The Berkshire Polx 1200 wipe is the stocked low particle count, 100% knit polyester wipe. This wipe is not as absorbent as the Spec-Wipe 3, but generates fewer particles. Dragging the sampling tube across the surface of a Berkshire Polx 1200 wipe resulted in lower than class 100 level particle counts.

4.10.4. To summarize, the Nanofab is meeting and exceeding design specifications for particle counts. If you would like to further reduce particles on your substrates, you may implement the following practices, in order of effectiveness:

4.10.4.1. Use only Berkshire Polx 1200 wipes if your process requires placing your substrate on a wipe

4.10.4.2. Use a facemask if your process requires you to work above your substrate on a table. Facemasks do not reduce particle counts on substrates in wet benches.

#### 4.11. **Procedure for the Use and Handling of Precious Metals**

4.11.1. Gold, platinum, palladium, and various alloys of these metals are stocked by the UCSB Nanofab. Each research group can be issued a precious metal supply. This supply must be stored in a small lockable container, along with a log sheet for recording the use of these metals. Precious metals, the lockable security container, and log sheets will be issued by the Nanofab manager. All use of precious metals must be accurately recorded on the log sheet, and include user name, date, metal type, metal weight before use, and metal weight after use. Multiple digital scales have been acquired and placed throughout the Nanofab to facilitate weighing of these metals. When requesting additional precious metals, the completed log sheet must be presented to the Nanofab manager. Any discrepancies in recorded precious metal use will result in charges to the principle investigator corresponding to the value of the precious metal discrepancy.

## 5. Communications and Internet Access

### 5.1. Wireless Access in the Nanofab and Courtyard Café

Currently, we have two wireless networks available to Nanofab users:

#### 5.1.1. Nanofab Wireless Access:

The Nanofab has three access points located in the Nanofab. This network is operated by Nanofab staff, and offers anonymous access. You may connect to this network by selecting the following network and entering the password.

network: nanofab

password: ece!nanofab

#### 5.1.2. UCSB Wireless Network

The Courtyard Café, as well as other locations on campus, provide access to the UCSB wireless network.

##### 5.1.2.1. External Users (Other universities or industrial users)

Access accounts to external Nanofab user (other university or industrial users) are provided as requested by the Nanofab manager. Please contact the Nanofab manager if you would like an account.

##### 5.1.2.2. Local academic users (UCSB grad students, staff, etc)

Local academic users can access the UCSB wireless network by using their UCSBNetID and password. Information regarding setup of a UCSBNetID and password:

<https://my.sa.ucsb.edu/U-reset/AccountManagement.aspx>

## 6. Ball Bonding, Wire Bonding, and Packaging Services

We have established an arrangement with PLT Technology to provide various ball bonding and packaging services to UCSB Nanofab users. The service can be provided for you by PLT technology, a local Santa Barbara company, and will be invoiced to your PI through our normal Nanofab recharge system. This service is offered to both academic and industrial Nanofab researchers. A description of the services and associated rates is below. Peter Tihanyi of PLT Technology will provide the service. Peter has a high level of expertise with these processes, especially involving unique or research-type substrates and processes. If you would like to utilize Peter's services, please contact Peter by email to start the process. All equipment noted below is in-house at PLT and in good working condition.

Peter Tihanyi  
PLT Technology, Inc  
420 East Haley Street  
Santa Barbara, CA 93101  
Phone: 805-962-1266  
Fax: 805-961-1713  
[www.plttechnology.com](http://www.plttechnology.com)

pltlaser@silcom.com

## Engineering II Nanofab Policy and Guidelines

- 6.1. Au wire bonding service using K&S model 4124 gold ball bonder. The charge is \$120 for the setup of the system and a minimum charge of \$120, which includes up to 20 Au wires bonded. Each additional set of 20 wires is \$120.
- 6.2. Semiconductor device soldering (laser diodes, other lasers, electronics, etc) using indium deposition on a heat sink in high vacuum ( $3 \times 10^{-7}$  torr). Device placement is accomplished using a Royce model 110 pick and place station with  $\pm 0.5 \mu\text{m}$  accuracy on heat sink, with flux/organics free soldering in a vacuum chamber using protective gas during the soldering process. This flux-free soldering process was developed by Peter Tihanyi for spacecraft applications. The charge for this process is \$120 per hour. There is a minimum charge of 8 hours for each soldering process which includes deposition of indium, chip placement, and chip soldering. The number of devices that can be soldered at the same time depends primarily on the heat sink size. We can supply C-mounts and 9mm packages for \$30 each.
- 6.3. Vacuum or N<sub>2</sub> back-fill of 9mm and TO-3 packages utilizing a POLARIS Accu-Weld 4000 tool. This tool can also be setup for other package configurations. PLT has fixtures for both 9mm and TO-3 packages. However, new fixturing will be required for other package types. The service for 9mm and TO-3 packages up to 10 pieces is \$800. We can supply the package for \$30 each.
- 6.4. Laser diode testing for wavelengths from 400nm to 1600nm utilizing a ILX Lightwave model LPA-9084 laser diode parameter analyzer. The charge is \$120 per hour for C-mount. The use of other package types is dependent on the heat sink size, but many other package types can be accommodated.
- 6.5. Semiconductor substrate scribe and break service utilizing a Loomis model 100 LSD tool. The setup charge is \$120, with a rate of \$120 per hour.
- 6.6. Lapping and polishing service utilizing a Logitech model PM2 tool. The rate is \$120 per hour, with a minimum of 8 hours. Various substrate materials can be processed, including Ga and InP.

## 7. **Fostering SEI Research at NNIN**

Through our participation in the National Nanotechnology Infrastructure Network (NNIN), we are committed to fostering research on the social and ethical implications of nanotechnology. Nanofab users are at the forefront of nanotechnology and can offer unique insight into this research. To this end, from time to time, users may be invited to participate in a research project, such as by answering a survey or participating in an interview. Although users are free to decline, and their decision to participate or not to participate will have no bearing on their ability to use the Nanofab, we sincerely hope that users will consider each request and accept as many invitations as they can in the spirit of advancing knowledge on social and ethical issues and helping to ensure that NNIN remains a leader in nanotechnology innovation. We are also committed to ensuring that these projects are relevant to NNIN, unburdensome to its users, and have met appropriate ethical standards. Thus, we will only release users' contact information to projects that have received prior approval from NNIN.

If you have any questions, please contact NNIN's Director, Dr. Sandip Tiwari [st222@cornell.edu](mailto:st222@cornell.edu) or NNIN's SEI Coordinator, Dr. Katherine McComas [kam19@cornell.edu](mailto:kam19@cornell.edu).

## 8. **Nanofab Summer Intern Policy**

Whenever the intern is in the Nanofab, the mentor must also be in the Nanofab. Interns may use tools that do not require training sessions, such as microscopes, etc, unless the supervisor of these tools objects. Interns can work at photolith benches, and use components of the photolith benches, unless the supervisor of the bench objects. Interns will need to follow normal Nanofab access procedures, including initiation meeting with the Nanofab manager.

Interns will be allowed to use one or two mainline Nanofab tools after completing training conducted by Nanofab staff. Mainline tools are tools scheduled through our web site [signupmonkey](#). Certain tools will be unavailable to interns due to extremely heavy use or other concerns.

## Engineering II Nanofab Policy and Guidelines

### 8.1. Tools unavailable for intern use during Summer 2012:

- 1.7 Stepper #1 (GCA 6300)
- 1.8 Stepper #2 (GCA AutoStep 200)
- 1.9 Stepper #3 (ASML)
- 1.10 E-Beam Lithography Tool (JEOL JBX-6300FS)
- 1.11 AFM-based Nanolithography Tool (NanoMan)
- 1.14 Wafer Bonder (Suss SB6-8E)
- 1.16 Holographic Lithography System
- 2.3 E-beam Evaporator #3 (Temescal)
- 2.4 E-beam Evaporator #4 (CHA)
- 2.5 Sputter Tool #1 (Custom)
- 2.6 Sputter Tool #2 (SFI)
- 2.9 Sputter Tool #5 (Lesker)
- 2.14 VLR PECVD (Unaxis)
- 2.15 Ion Beam Deposition Tool (Veeco Nexus)
- 3.1 RIE #1 (Custom)
- 3.4 RIE #5 (PlasmaTherm SLR)
- 3.5 RIE Bosch (PlasmaTherm SLR ICP)
- 3.7 VLR Etch (Unaxis VLR)
- 3.8 ICP Etch #1 (Panasonic)
- 3.9 ICP Etch #2 (Panasonic)
- 3.12 XeF2 Etch (Xetch)
- 3.13 Plasma Activation Tool (EVG 810)
- 3.14 HF Vapor Etch
- 4.3 Wet Etch Benchesn (Acid etch and HF etch)
- 4.4 Wet Etch Wafer Scale Bench (Acid etch and HF etch)
- 4.10 Chemical Mechanical Polish (Logitech)
- 5.1 Rapid Thermal Processor (AET RX6)
- 6.2 Flip Chip Bonder (Finetech)
- 6.4 Dicing Saw (ADT)
- 7.1 Field Emission SEM #1 (FEI)
- 7.2 Field Emission SEM #2 (JOEL)
- 7.14 Surface Analysis (KLA/Tencor Surfscan)
- 7.20 Deep UV Optical Microscope (Olympus)